

1.002 WINDOWS

single opening window with fixed side light

EN763 PVC

ENERGATE

WWW.ENERGATE.COM

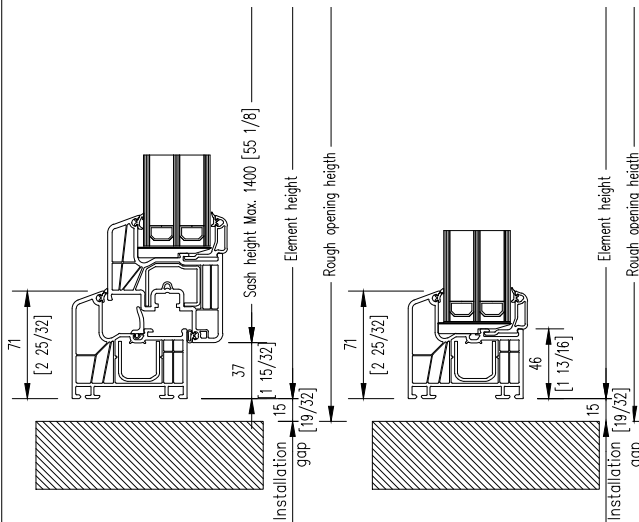
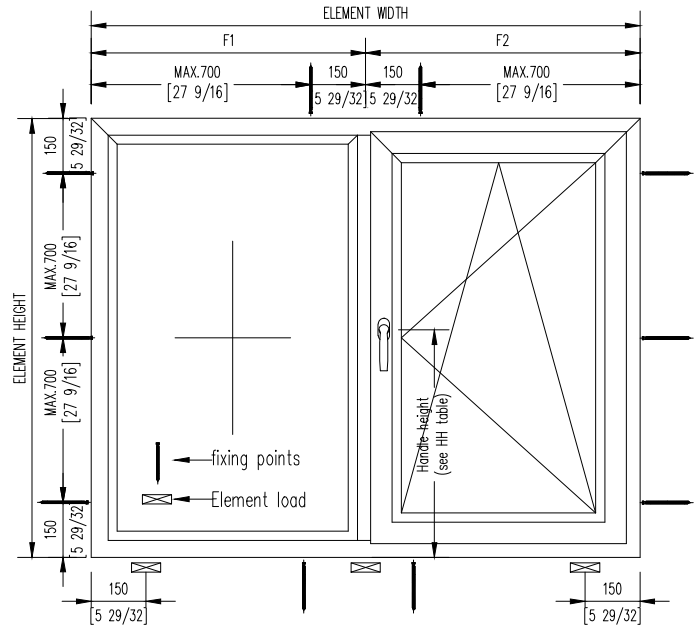
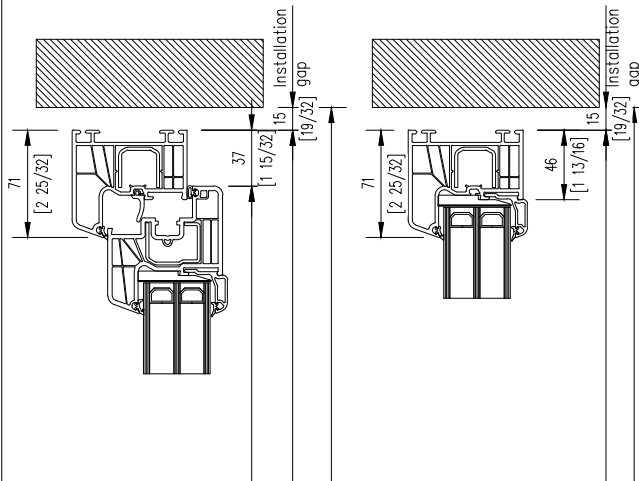

System:	ENERGATE 763
ENERGATE product type:	1.002
Security level:	Basic
Standard handle:	Atlanta
Shaft length 7x7x35mm (17/64" x 17/64" x 1 3/8")	
Screws M5 x 50mm (M5 x 1 31/32")	
Sash weight (max. kg)	100 kg
Minimum & maximum measurements:	Information at the drawing.
Attention: Minimum and maximum dimensions can not be combined	
For exact information see ENERGATE size application diagram (separate page)	
Maximal sizes always depend on weight are of the chosen glass.	
The glass weight is always noted on the product data sheet.	

