

**1.004**  
**WINDOWS**  
 double french opening window

EN763 PVC

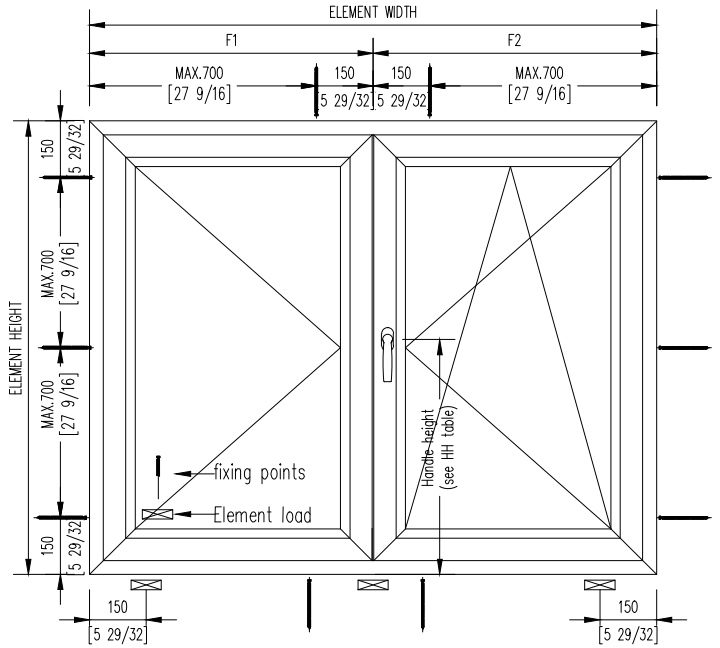

System:	ENERGATE 763
ENERGATE product type:	1.004
Security level:	Basic
Standard handle:	Atlanta
Shaft length 7x7x35mm (17/64" x 17/64" x 1.3/8") Screws M5 x 50mm (M5 x 1.31/32")	
Sash weight (max. kg)	100 kg
Minimum & maximum measurements: Attention: Minimum and maximum dimensions can not be combined For exact information see ENERGATE size application diagram (separate page) Maximal sizes always depend on weight and are of the chosen glass. The glass weight is always noted on the product data sheet.	Information at the drawing.

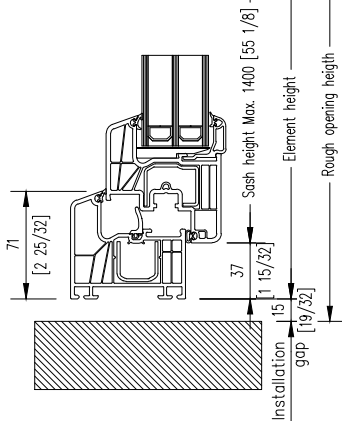
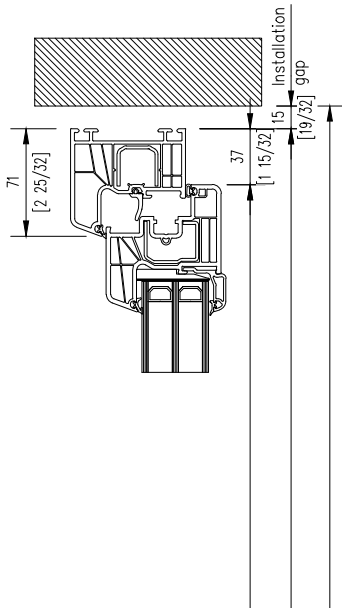