

1.104

PATIO DOORS with flat threshold
double french opening swinging door

EN763 PVC

ENERGATE

WWW.ENERGATE.COM

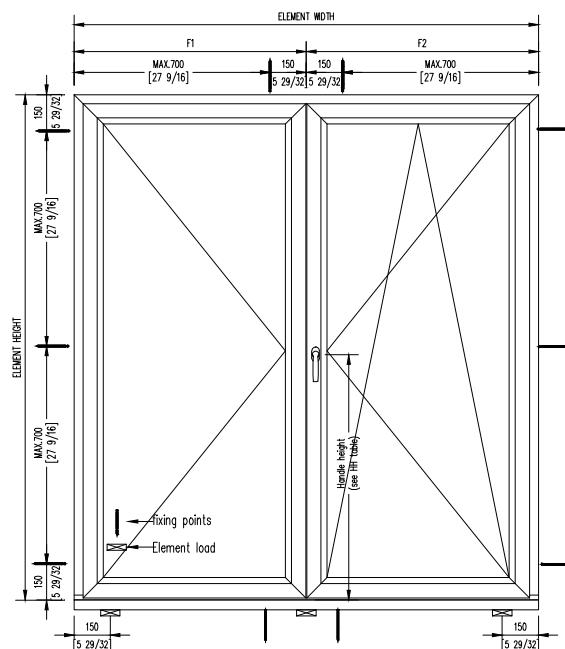
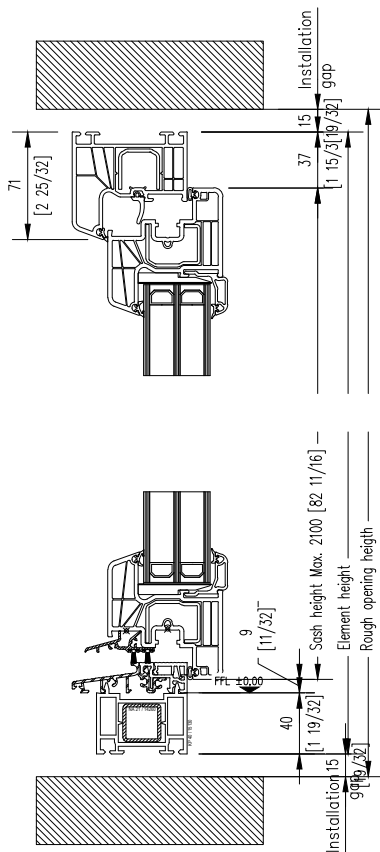

System:	ENERGATE 763
ENERGATE product type:	1.104
Security level:	Basic
Standard handle:	Atlanta
Shaft length 7x7x35mm (17/64" x 1 3/8")	
Screws M5 x 50mm (M5 x 1 31/32")	
Sash weight (max. kg)	100 kg
Minimum & maximum measurements:	Information at the drawing.
Attention: Minimum and maximum dimensions can not be combined	
For exact information see ENERGATE size application diagram (separate page)	
Maximal sizes always deponed on weight are of the choosen glass.	
The glass weight is always noted on the product data sheet.	

