

1.001
PATIO DOORS
 single opening window

EN802 Wood

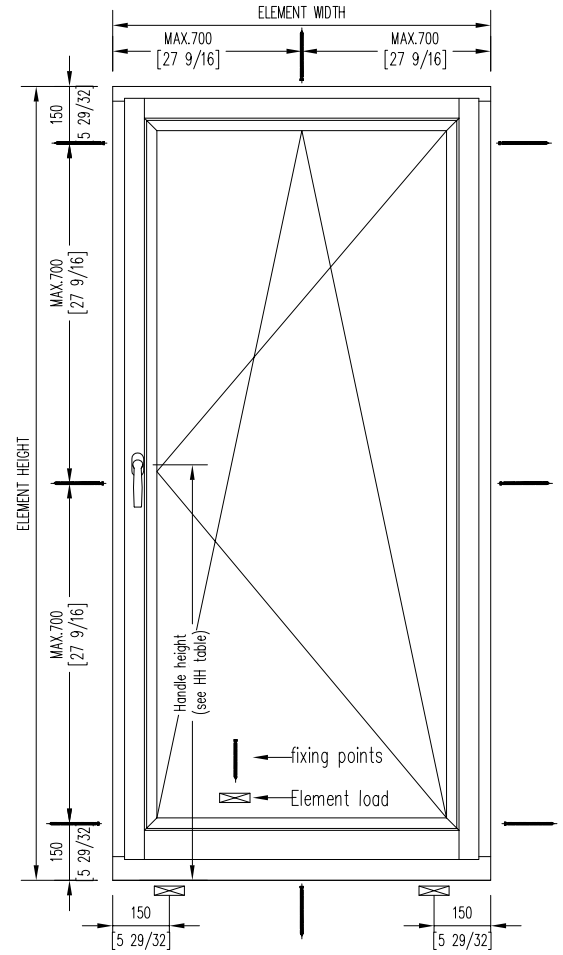

System:	ENERGATE 802[+]
ENERGATE product type:	1.001
Security level:	Basic
Standard handle:	Atlanta F1 (silver)
Shaft length 7x7x35mm (17/64" x 17/64" x 1 3/8")	
Screws M5 x 50mm (M5 x 1 31/32")	
Sash weight (max. kg)	150 kg
Minimum & maximum measurements:	Information at the drawing.
Attention: Minimum and maximum dimensions can not be combined	
For exact information see ENERGATE size application diagram (separate page)	
Maximal sizes always depend on weight area of the chosen glass.	
The glass weight is always noted on the product data sheet.	

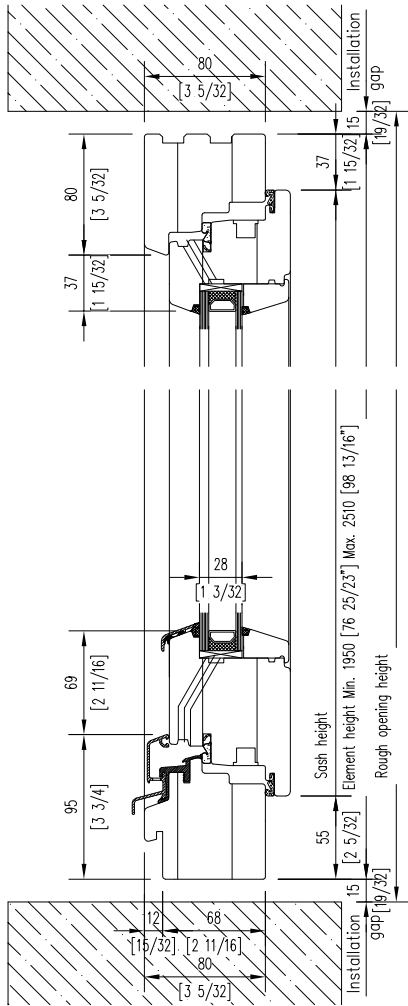