

1.004

WINDOWS

double french opening window

EN802 Wood

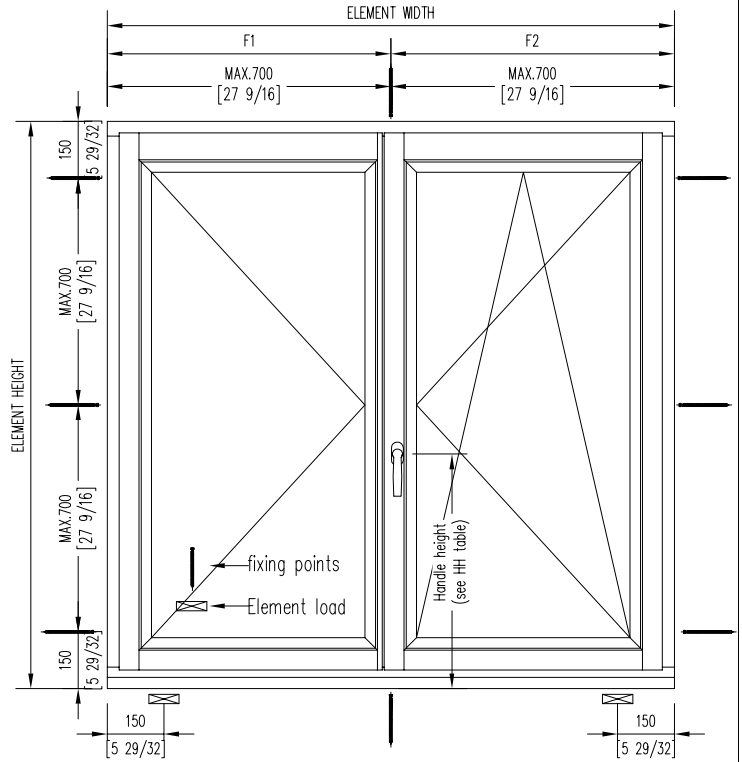
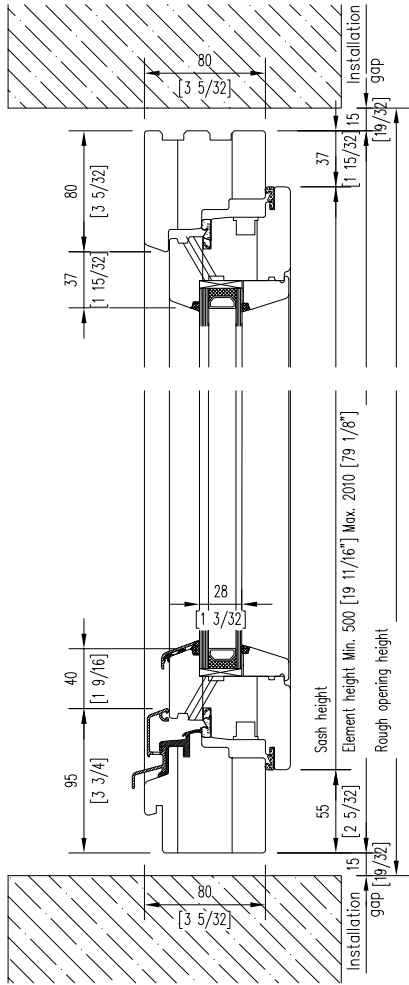

System:	ENERGATE 802[+]
ENERGATE product type:	1.004
Security level:	Basic
Standard handle:	Atlanta F1 (silver)
Shaft length 7x7x35mm (17/64" x 17/64" x 1 3/8")	
Screws M5 x 50mm (M5 x 1 31/32")	
Sash weight (max. kg)	150 kg
Minimum & maximum measurements:	Information at the drawing.
Attention: Minimum and maximum dimensions can not be combined	
For exact information see ENERGATE size application diagram (separate page)	
Maximal sizes always deponed on weight are of the chosen glass.	
The glass weight is always noted on the product data sheet.	

