

5.051.3

LOCKABLE PATIO DOORS with flat threshold
single outward opening swinging patio door with lever
handle set for framed doors, handle inside and outside

EN802 Wood

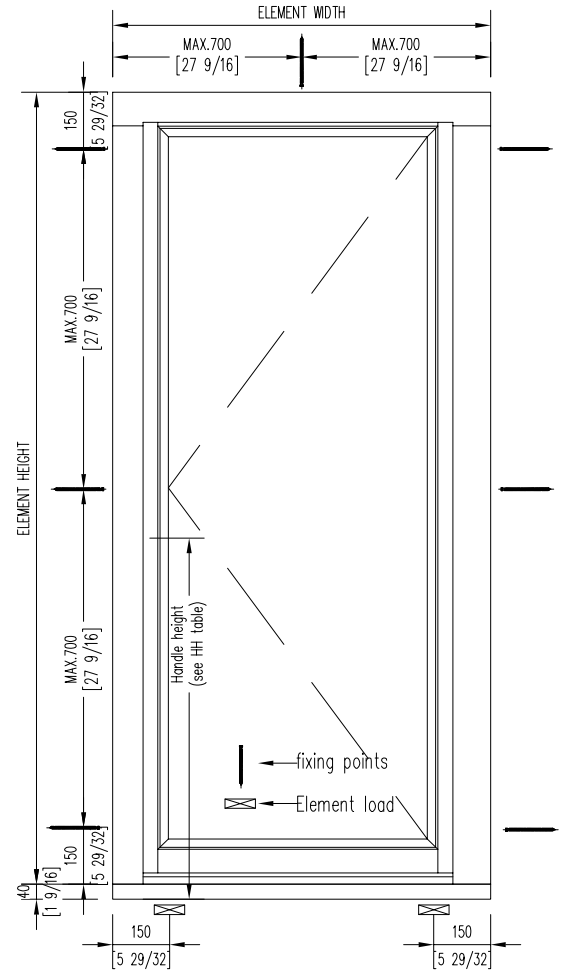
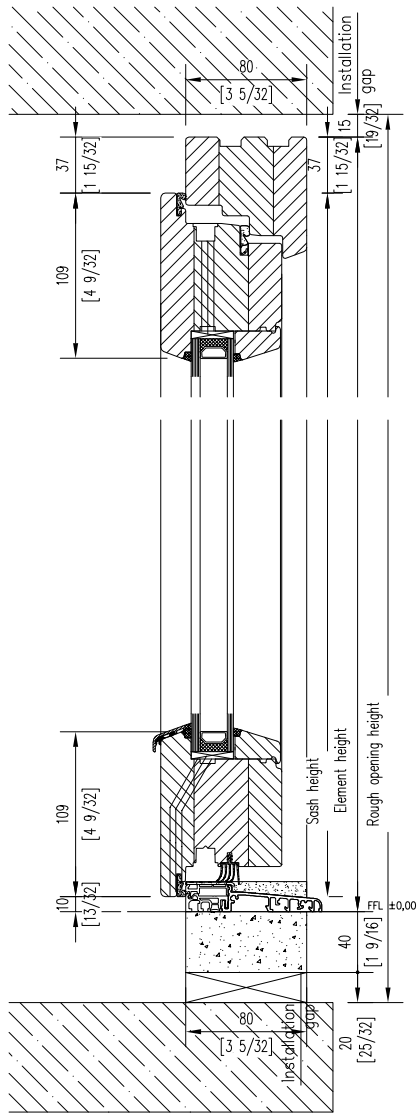

System:	ENERGATE 802[+]
ENERGATE product type:	5.051
Security level:	Basic
Standard handle:	
Sash weight (max. kg)	150 kg
Minimum & maximum measurements: Attention: Minimum and maximum dimensions can not be combined For exact information see ENERGATE size application diagram (separate page) Maximal sizes always depend on weight and are of the chosen glass. The glass weight is always noted on the product data sheet.	Information at the drawing.

