

1.004
WINDOWS
double french opening window

EN843 PVC

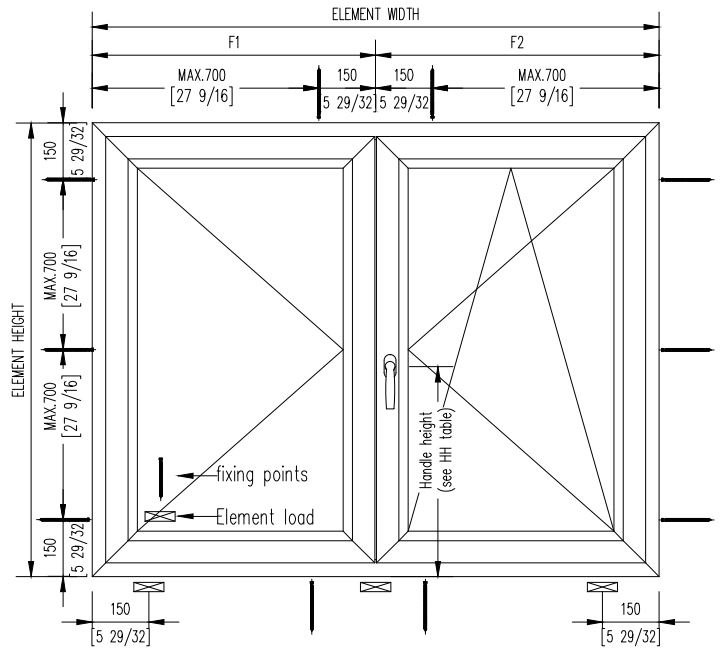

System:	ENERGATE 843
ENERGATE product type:	1.004
Security level:	Basic
Standard handle:	Atlanta
Shaft length 7x7x35mm (17/64" x 17/64" x 1 3/8")	
Screws M5 x 50mm (M5 x 1 31/32")	
Sash weight (max. kg)	100 kg
Minimum & maximum measurements:	Information at the drawing.
Attention: Minimum and maximum dimensions can not be combined	
For exact information see ENERGATE size application diagram (separate page)	
Maximal sizes always depend on weight and are of the chosen glass.	
The glass weight is always noted on the product data sheet.	

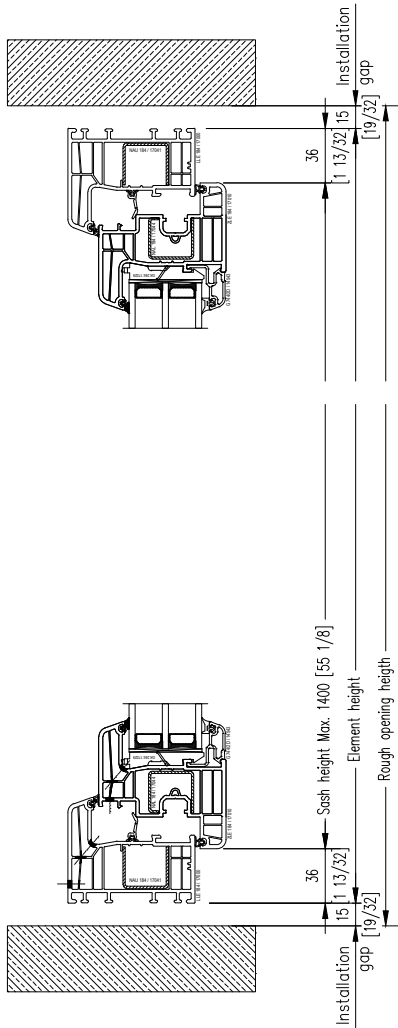