

1.001
WINDOWS
single opening window

EN893

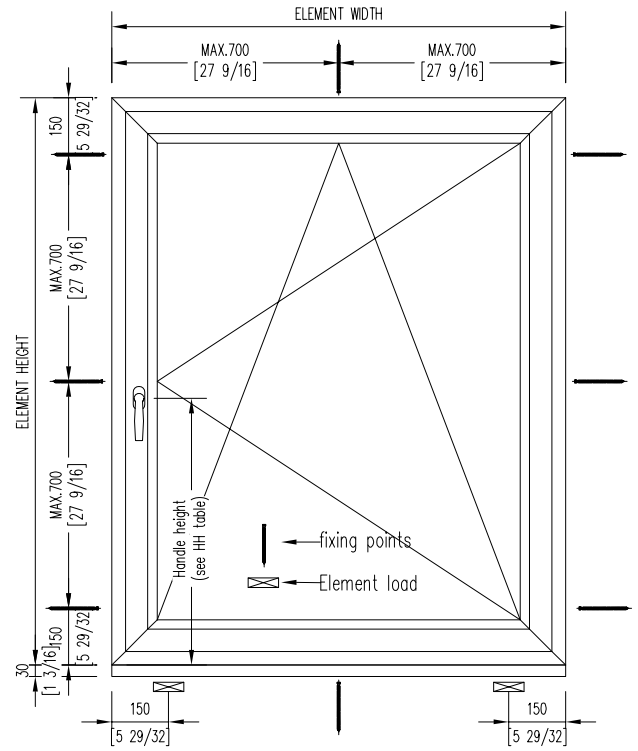

System:	ENERGATE 893
ENERGATE product type:	1.001
Security level:	Basic
Standard handle:	Atlanta
Shaft length 7x7x35mm (17/64" x 17/64" x 1.3/8") Screws M5 x 50mm (M5 x 1.31/32")	
Sash weight (max. kg)	100 kg
Minimum & maximum measurements: Attention: Minimum and maximum dimensions can not be combined For exact information see ENERGATE size application diagram (separate page) Maximal sizes always deponed on weight are of the choosen glass. The glass weight is always noted on the product data sheet.	Information at the drawing.

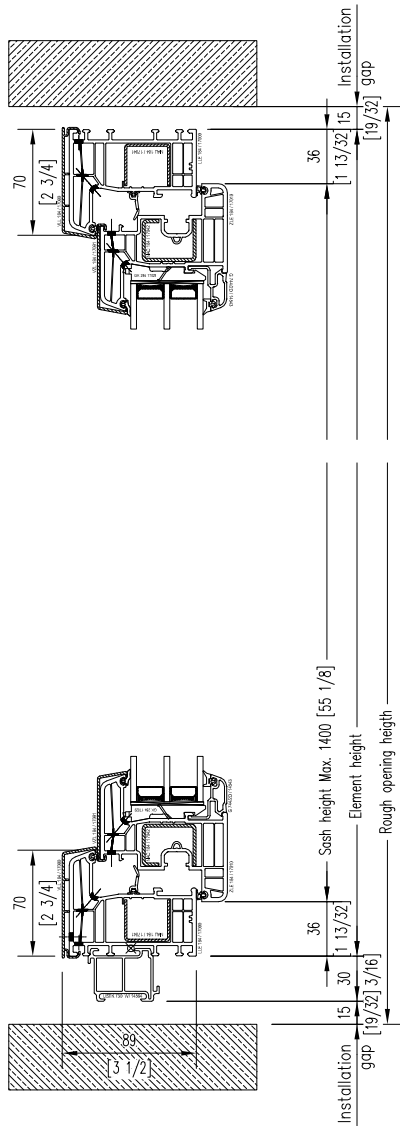